



# TIMING MODULE

FULLY SOLID STATE ENCAPSULATED  
 ONE AMPERE LOAD RATING  
**Series 604 - ONE SHOT**  
 CMOS DIGITAL CIRCUITRY

  
 E75633 LR46938

- Life Expectancy –unlimited
- Environment Protected
- Tamper Proof
- No False Operate
- Small Size – 2"x 2" x 53/64"
- Lightweight – approximately 2.5 oz.
- Rugged

Input power is applied continuously. The first closure, momentary or sustained, of a normally open isolated initiate switch simultaneously starts timing of the preset delay period, and turns the load ON. At the end of the preset delay time the load turns OFF. Should a sustained isolated initiate switch closure be used to start timing it is necessary to open this switch to permit reset of the timer before the next cycle can occur. Re-closure of the initiate switch during timing has no effect.

Control the timing of valves, SFHP motors, lamps, relays, magnetic line starters, and actuators rated less than 1 ampere (10 amps inrush). CMOS digital circuitry, with solid state output switching. P/C boards and internal components are encapsulated in a flame retardant molded housing, fitted with quick connect wiring terminals. Available in all standard voltages and frequencies. Fixed or adjustable timing from .1 seconds to 24 hours.

## TIMING DIAGRAM

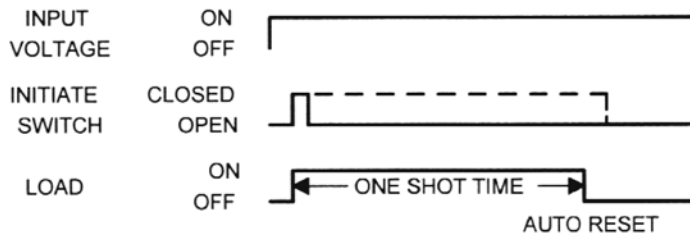

## SPECIFICATIONS

1. Repeat Accuracy:  $\pm 0.1\%$  or 16 ms. Whichever is greater
2. Combined Effect of Temperature and Voltage upon Repeat Accuracy:  $\pm 1\%$
3. Reset Time: 150 ms.
4. Operating Voltage Tolerance:  $\pm 20\%$
5. Load Current: Steady State – 8 ma. Min., 1 Ampere Max.
- 6 Voltage Drop: 1.5V Typical at 1 Ampere
7. Leakage Current: 5 ma.
8. Dielectric Strength: 1500 VRMS
9. Insulation Resistance: 100 Megohms Min.
10. Input Transient Protection: 3000V 120V UNITS, 6000V 240V units
11. Temperature Ambients: Operating -40°C to +70°C, Storage -55°C to +70°C
12. Humidity-Operating: 95% Relative
13. Linearity (Option A or D):  $\pm 5\%$  Minimum from 10% to 90% of ra
14. Timing Tolerance:  $\pm 9\%$  + Tolerance of Rt Std.,  $\pm 5\%$  Special (Fixed)

## HOW TO ORDER 604 – (T) (V) (P)

SERIES	(T) = TIME RANGE	(V)=VOLTAGE	(P) = OPTIONS
604	P = 0.1 - 5 SEC.	1 = 12VDC	O - CUSTOMER SUPPLIES OWN POTENTIOMETER OR RESISTOR A - POTENTIOMETER SUPPLIED AS LOOSE PART *B - EXTERNALLY INSTALLED RESISTOR *C - FACTORY FIXED INTERNAL D - TRIMMER POTENTIOMETER INSTALLED ON TERMINALS R - INTERNAL POTENTIOMETER WITH THRU SHAFT S - INTERNAL POTENTIOMETER WITH SCREWDRIVER SLOT  <div style="border: 1px solid black; padding: 5px; text-align: center;"> <i>* For Fixed Time Specify The Value In Seconds, Minutes, Or Hours</i> </div>
	1 = 0.1 - 10 SEC.	2 = 24VDC	
	L = 0.2 - 20 SEC.	3 = 48VDC	
	J = 0.3 - 30 SEC.	4 = 24VAC	
	M = 0.6 - 60 SEC.	5 = 120VAC	
	2 = 1 - 100 SEC.	6 = 240VAC	
	K = 1.2 - 120 SEC.		
	F = 2 - 180 SEC.		
	E = 3 - 300 SEC.		
	3 = 10 - 1000 SEC.		
	4 = 0.1 - 10 MIN.		
	G = 0.3 - 30 MIN.		
	H = 0.6 - 60 MIN.		
	5 = 1 - 100 MIN.		
V = 3 - 300 MIN.			
6 = 10 - 1000 MIN.			
D = 1 - 24 HRS.			

**MADE IN USA**

**EXAMPLE P/N: 604-36C/200S** This is a ONE SHOT 1A Rated Solid State Timer with a 200 second DELAY and an INPUT VOLTAGE of 240 VAC. The DELAY is FACTORY FIXED INTERNAL calibration.

American Control Products / Precision Timer  
 a division of Prime Technology  
 344 Twin Lakes Road  
 North Branford, CT 06471  
 Telephone: (203) 481-5721  
 Fax: (203) 481-8937  
 Email: sales@primetechnology.com  
 www.primetechnology.com



## TECHNICAL BULLETIN

### SOLID STATE TIMING MODULE

PAGE 1  
OF 2

DATE  
6-4-01

**604**

REV  
B

## CALIBRATION RESISTANCE VS TIME

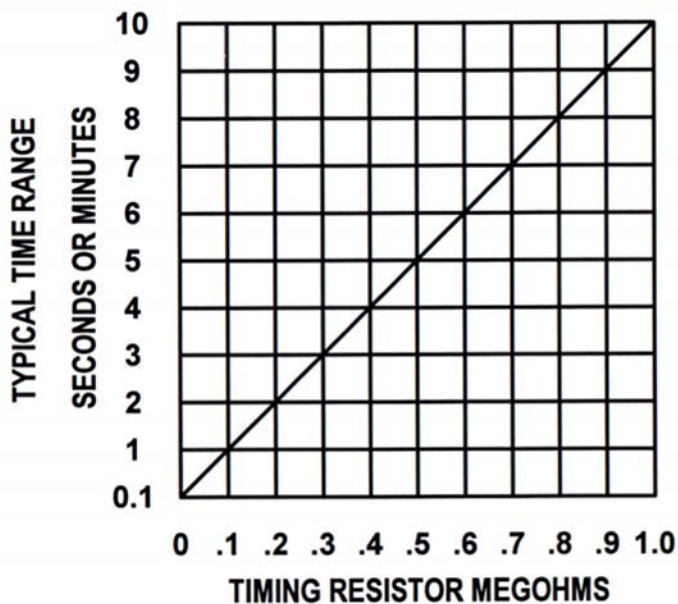

## ACCESSORIES – AVAILABLE FROM STOCK

ORDER P/N: **PM – 1M 1 MEGOHM ± 20%**  
**PM – 100K 100 KOHM ± 20%**

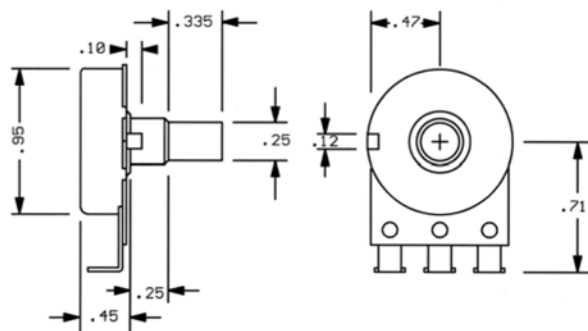

## TYPICAL WIRING

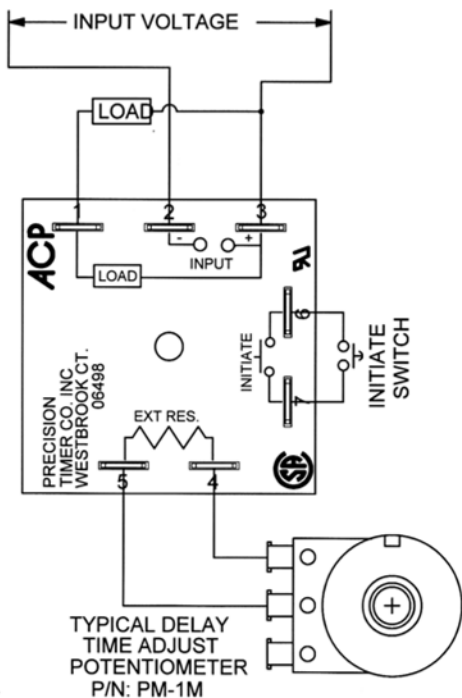

## OUTLINE DRAWING

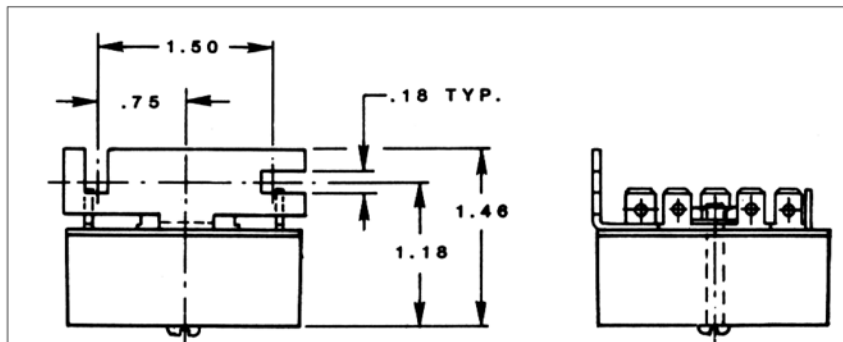
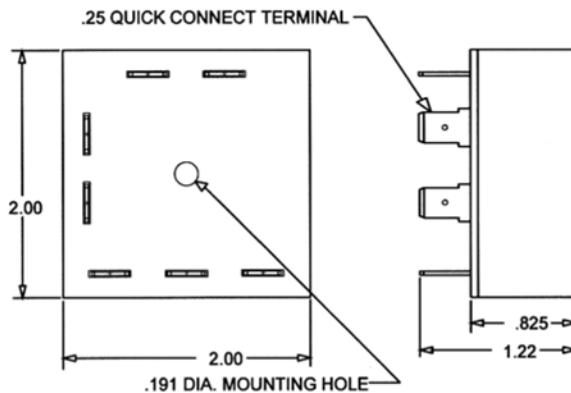

Order bracket mount model as: 604BM – (T) (V) (P)

**MADE IN USA**



American Control Products / Precision Timer  
 a division of Prime Technology  
 344 Twin Lakes Road  
 North Branford, CT 06471  
 Telephone: (203) 481-5721  
 Fax: (203) 481-8937  
 Email: sales@primetechnology.com  
 www.primetechnology.com

## TECHNICAL BULLETIN

## SOLID STATE TIMING MODULE

PAGE 2  
OF 2

DATE  
6-4-01

**604**

REV  
B